



HIGH SPEED WRAP LABELER

CVC 302



The CVC 302 High Speed Wrap Labeler is built to automatically apply pressure sensitive labels onto round containers at up to 200 bottles per minute. The 302 is servo motor controlled, comes standard with a touch screen HMI, and can be ordered with various inspection options including bar code verification, vision, and missing label detection. The 302 is an ideal machine for contract packagers and manufacturers serving the pharmaceutical, nutraceutical, and food markets.

The CVC 302 can run stand alone or integrated into a full packaging line.

STANDARD FEATURES

- Self-Set Auto Adjusting Control System
- Stainless Steel Frame on lockable casters
- Stainless Steel sanitary bed conveyor with 4" wide ground down table top chain.
- Touchscreen HMI
- Label head with up to $\pm 1/32$ " accuracy (*bottle dependent)
- Integrated Wrap Station
- Servo motor with PLC controls
- Adjustable Tilt for Tapered Bottles
- Label Sensor for Paper or Opaque Labels
- Product Sensor w/ Opaque & Clear Bottle Mode
- Variable Speed Separator Wheel



All CVC labelers include our patented Self Set™ software which utilizes a high frequency encoder for extremely easy setup and wrinkle free labeling at the touch of a button.

CVC 302 Technical Specifications

Speed	Up to 150 Bottles per Minute (BPM)
Bottle Height	1" to 12" (25mm - 305mm)
Bottle Diameter	1" to 7" (25mm - 178mm) dependent on conveyor width
Label Width / Height	3/8" to 7" (10mm - 178mm) dependent on label head type
Label Length	1/2" to 12" (13mm - 305mm)
Label Roll	Max 16" (356mm) outside diameter with 3" core
Dispense Speed	Max 75 meters / min.
Conveyor Width	Standard 4" (also available in 6")
Conveyor Length	Standard 121" (also available in 94" sanitary)
Conveyor Bed Height	Standard 36" (+/- 2")
Power	220V, 50/60 Hz, Single Phase, 6 Amp
Air Pressure	Minimum 85 psi (ISO 8573-1)
Air Consumption	4 cfm (for optional reject and Lot/Date printer)
Machine Weight	350 kg

TECHNICAL SPECIFICATIONS

AVAILABLE OPTIONS

- Hot Stamp (Lot/Date Coding)
- Integrated Thermal Encoder (Lot/Date, Bar Code and Graphics)
- Bottle Rejection System (Air Blow or Cylinder)
- Clear Label Sensor
- Custom Wrap Belts
- Feed Screw
- Infeed and Outfeed Conveyor Extensions
- Laser Bar Code Verification
- Loading and Collecting Turn Tables
- Low Label Sensor (Factory Installed Only)
- Missing Label Detection System (UV)



THERMAL TRANSFER PRINTER



VISION INSPECTION SYSTEMS

MACHINE LAYOUTS

Top View

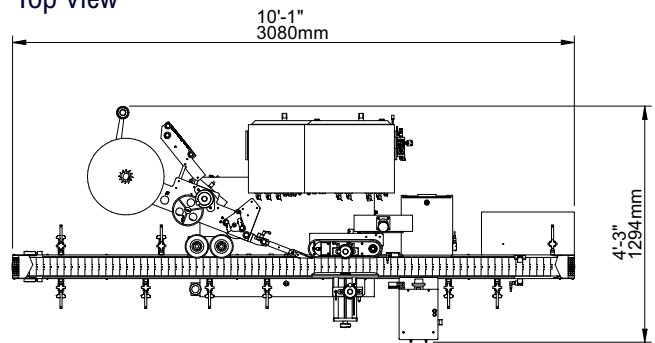

Front View

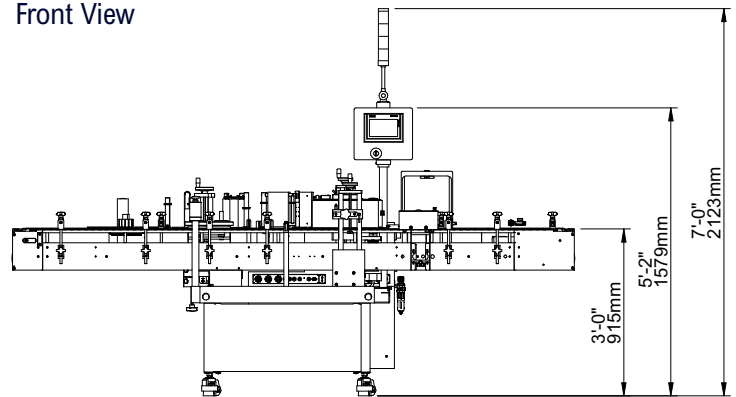

The dimensions shown are for standard machine. The conveyor can be extended: the length may vary based on selected options. This machine can run independently or be integrated into an automated packaging line. All CVC equipment is covered by a one-year parts warranty. Full Warranty details are included in our equipment proposals or can be found on our website.



Contact Us

USA
10861 Business Drive, Fontana, CA 92337
Phone: +1 (909) 355-0311
www.cvctechnologies.com
sales@cvcusa.com

USA East Coast Office
1855 New Highway, Suite C, Farmingdale NY 11735
sales@cvcusa.com

Taiwan-Asia Pacific Headquarters
Phone: +886 (4) 2496-3666
sales@cvctechnologies.com

China/India
sales@cvctechnologies.com